

Introduction

Pressure Loading and Relief Valves are fittings for dosing plants. They are used, according to the user's requirements, to increase dosing accuracy or to protect the plant against excess pressure.

Where the supply pressure is higher than the dosing pressure, dosing is not possible without a pressure loading valve.

Important

This fitting must not be used as a non-return valve to prevent reverse flow.

Design

The fittings are spring loaded diaphragm valves with a small proportional range. In the uPVC and stainless steel models, the spring cover is made of PPh.

Pressure Loading Valve

Pressure sustaining Valves are required if the dosing pump has to deliver against sharply fluctuating system pressures, or into 'open-ended' systems (diag. 1). In the first case, the dosing accuracy would be unnecessarily reduced (especially in the case of diaphragm dosing pumps). In the second case, excess delivery can easily occur, since - due to inertia - the accelerated delivery medium continues to flow, unrestricted, although the delivery stroke is completed. There would likewise be an uncontrollable flow if the supply pressure upstream of the suction valve is higher than the system pressure. Here again the pressure loading valve is used to create an artificially higher system pressure for the benefit of the dosing pump (diag. 2).

A pressure sustaining valve is not necessary where a hose injection fitting or spring-loaded ball injection fitting is used and the resulting back-pressure is sufficient (the injection fitting opening pressure).

Examples of Pressure Loading Valves in use

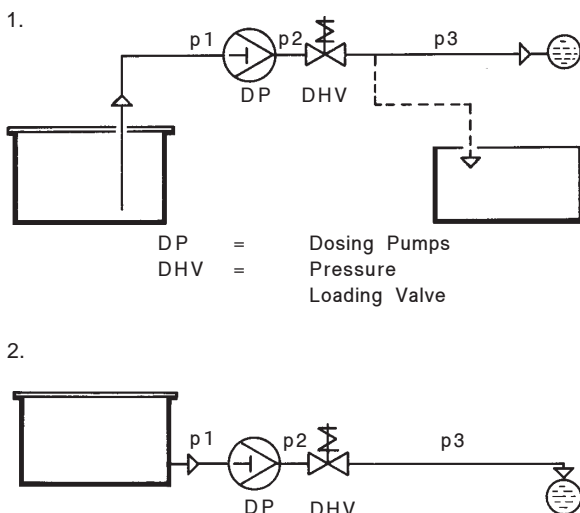

Relief Valve

Relief Valves act as safety measure, protecting the dosing pump and the associated fittings and pipes. They prevent an excessive pressure rise in the system upstream of the dosing pump, such as may occur for example if isolating valves are closed although the pump is still running. They should therefore always be included (diag. 3).

Relief valves can also be used where constant pressure is to be maintained in a supply line fed by a centrifugal pump. All the medium that is not taken up is returned to the tank via the relief valve (diag. 4).

Examples of Relief Valves in use

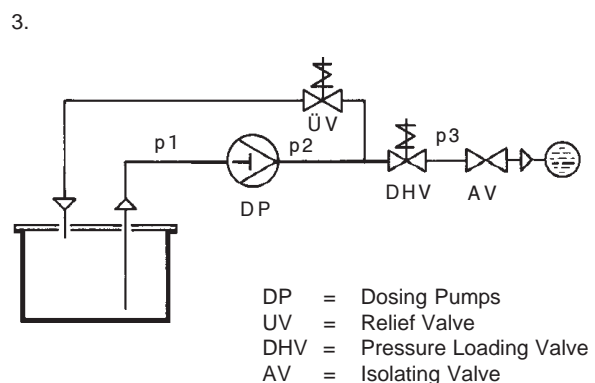

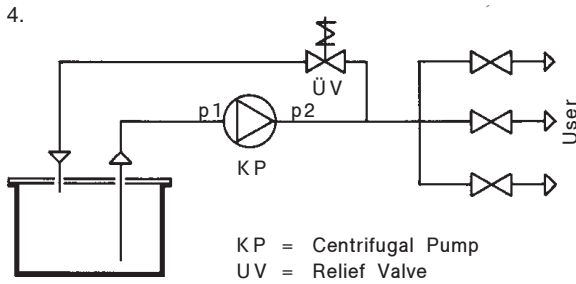

Relief valves are not absolutely necessary where the pump has a closed piston-diaphragm system with an integrated internal relief valve.

However, in plants where frequent relief is likely to occur, a relief valve should be provided even with piston-diaphragm pumps.

Selection

The selection criteria are:

1. Flow rating
2. Pressure
3. Permissible pressure drop in valve
4. Aggressive nature of the medium
5. Temperature of the medium
6. Type of connection

Flow Rating

The flow rating shown in the selection table applies to a constant flow of water and similar liquids, with reference to viscosity and density, as obtained with centrifugal pumps or reciprocating dosing pumps fitted with an adequate pulsation damper.

Where the flow is not constant (dosing pumps without pulsation damper), the supply rating of the dosing pump should be multiplied by 2 to 3 before selection the fitting.

Pressure Relationship

Pressure loading valves are set by preloading the spring at the desired opening pressure. This pressure must be such that during maximum flow no pressure occurs higher than is permissible for the dosing pump or other equipment in use.

Dimensions

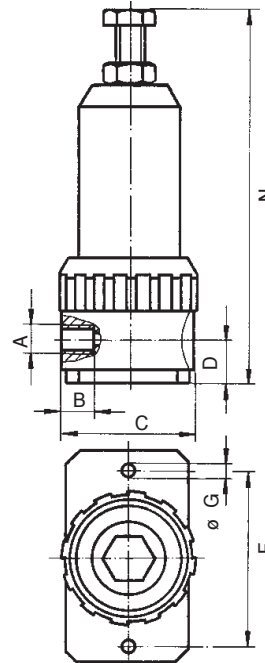

DN	A	B	C	D	N	F	Ø G
6	G 1/4	10	40	23	ca. 142	46,5	4,5
10	G 3/8	12	55	19	147	72	7
15	G 1/2	16	75	22	152	92	7

Valve Selection Table

The valves shown in the table allow for a pressure increase, for maximum flow, of approx. 1 bar above the opening pressure set.

It is important to note that increasing back-pressure does not lead to increasing pump pressure (as long as it remains below the set pressure), since the back-pressure also works against the spring in the opening direction.

Valves PN 10; max. 50 °C

Q*	DN	Casing/Diaphragm Materials		
		PVC/ PTFE	PVDF/ PTFE	1.4571/ PTFE
75	6	12532000	12532001	12532002
200	10	12532003	12532004	12532005
500	15	12532006	12532007	12532008

* Q= refer to paragraph on Flow Rating

Order Example

A uPVC pressure loading valve is required for a A 24 dosing pump with no pulsation damper. As there is pulsation in use, the flow is 24 l x 3 = 72 l.

Choice: DN 6 (75 l/h)

Part No: 12532000

Connection Selection Table

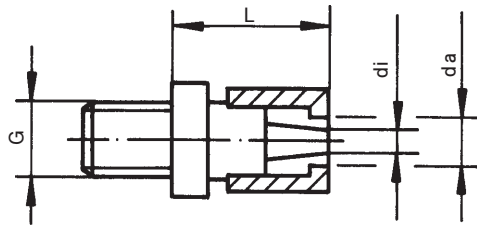

Type A
Hose Clamp Connection

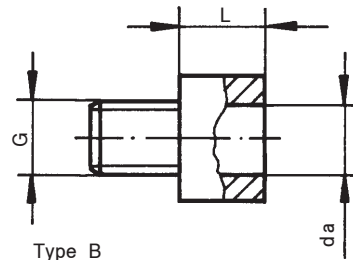

Type B
Hose clip Connection

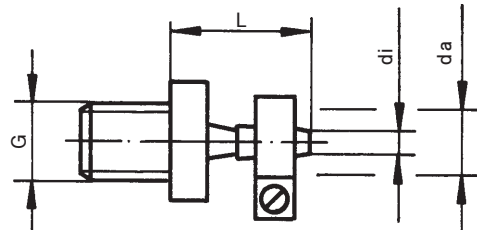

Type C
Solvent-cement jointed pipe Connection

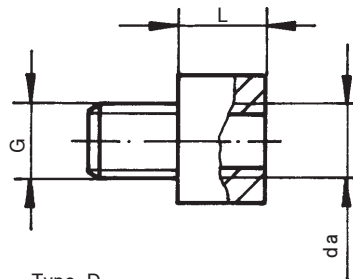

Type D
Threaded Connection

Connection A	DN	Pipe Conn.			PVC			1.4305	
		L	di	da	Type A	Type B	Type C	Type B	Type D
G 1/4	6	22	4	6	28125**	—	—	—	—
		35	6	8	26489	—	—	—	—
		24	6	8	—	—	—	26494	—
		44	6	12	26487*	—	—	—	—
		24	6	12	—	—	—	26495	—
		20	—	8	—	—	—	26497	—
		20	—	10	—	—	—	18995	—
G 3/8	10	18	—	12	—	—	21839	—	—
		35	9	15	—	32462	—	—	—
		32	9	15	—	—	—	26500	—
		18	—	12	—	—	82900	—	—
		18	—	16	—	—	82902	—	—
		18	—	20	—	—	82900	—	—
G 1/2	15	28	—	G 1/2	—	—	—	—	82956
		43	16	26	—	32461	—	—	—
		55	16	26	—	—	—	29376	—
		20	—	16	—	—	18932	—	—
		21	—	20	—	—	19143	—	—
		25	—	25	—	—	19581	—	—
		30	—	G 3/4	—	—	—	82135	

* 29796 (PVDF)

** 28125 (PPH)

Selection

Q l/h	DN	Valve housing:	
		PP (Plastic)	1.4571 (SS)
850	25	12521366	12531199
1400	32	12521368	12532446
2250	40	12521370	12532447
3600	50	12521372	12532448
5000	65	12521374	—
max. °C		40	50
max. bar		10	16

Plastic Construction
DN 25 ... 65
Stainless Steel Construction
DN 25

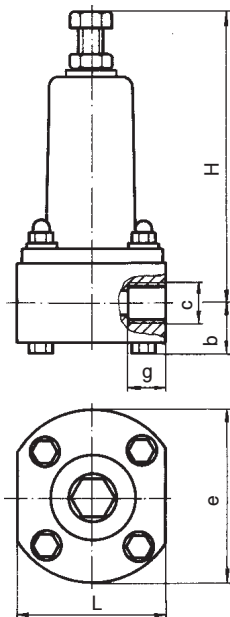

Stainless Steel Construction
Dn 32 ... 50

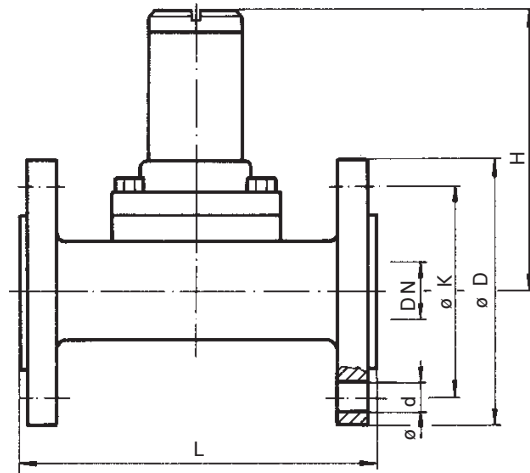
Dimensions

DN	PP						1.4571								
	H	b	c	g	e	L	H	b	c	g	e	f	D	k	d
25	240	41	G 1	20	149	140	235	32	G 1	30	149	140	—	—	—
32	242	41	G 1 1/4	22	149	140	165	—	DN 32	—	—	180	140	100	18
40	252	48	G 1 1/2	22	159	152	180	—	DN 40	—	—	200	150	110	18
50	260	48	G 2	27	170	156	185	—	DN 50	—	—	230	165	125	18
65	284	56	G 2 1/2	28	190	172	—	—	—	—	—	—	—	—	—

Connections

Type	DN	d	Size	PVC	1.4571
B	25	G 1	25	22694	—
D	25	G 1	ø 32	19384	—
	32	G 1 1/4	ø 40	20981	—
	40	G 1 1/2	ø 50	21380	—
F	25	G 1	—	21406	31194
	32	G 1 1/4	—	21410	—
	40	G 1 1/2	—	21414	—
	50	G 2	—	21416	—
	65	G 2 1/2	—	21418	—

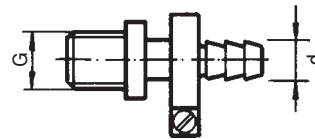

Hose spigot
Type B

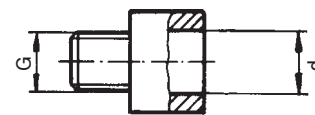

Solvent-cement jointed pipe
Connection
Type D

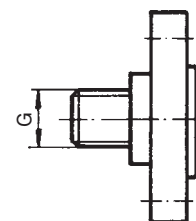

Flanged
Connection
Type F

Spring loaded pressure loaded and relief valve in stainless steel (1.4571)

Flow Rate: DN 6 40 l/h
 DN 10 100 l/h

Installation in any direction

Valve seat material: DN 6 Viton
 DN 10 Polyamid

Opening pressure
adjustabl between: DN 6 0,5 and 200 bar
 DN 10 16 and 300 bar

Temperature: DN 6 120 °C max.
 DN 10 50 °C max.

DN	Pressure range [bar]	Valve compl. Part No.	Spring Part No.	Valve seat Part No.
6	0,5 ... 2	12532421	32420	80085
	2 ... 15	12510269	19366	
	16 ... 25	12524121	19807	
	26 ... 37	12524125	20796	
	38 ... 48	12524124	20797	
	49 ... 65	12524122	19808	
	66 ... 90	12524123	19809	80792
	91 ... 120	12331900	31929	
	121 ... 200	12531901	31980	
10	*16 ... 300	12532444	32624	32625

*) Please specify operating or blowoff pressure when ordering.

DN 6

