

**Keep the operating instructions of the metering pump and the accessories readily accessible.**

**List of contents**

1. Technical data
2. Scope of delivery
3. Installation
4. Electrical connection of the pump
5. Safety instructions
6. Injection fitting assembly
7. Startup
8. Maintenance
9. Troubleshooting

**1. Technical data**

Minidos A...		3	5	8	14	24	40	
Max. pressure	[bar]	10					5	
Flow rate at	[l/h]	3.2	6.4	8	14	24	39*	
10 bar (* 5 bar)	[ml/str.]	1.5		2.6		4.7*		
Stroke frequency	[min-1]	36	72	90		138		
Diaphragm dia.	[mm]	38			52		64	
Suction lift	[mbar]	120						
Motor power	[kW]	0,03	0,05	0,03		0,05		
Max. temperature	[°C]	40						
Weight[kg]	Plastic	4.4			4.7			
Head of:	St. steel	4.7			7			

**2. Scope of delivery**

Be careful when unpacking the metering pump and possible accessories in order not to miss small parts. Compare the scope of delivery to the delivery note. If there are any discrepancies, try to find out the reason immediately.

**3. Installation**

For selection of a pump during construction of a plant as well as for installation and operation, the local rules must be observed. This applies to the selection of suitable pump materials, the handling of the chemicals and the electrical installation. At the same time the technical data of the metering pump according to the below table must be considered, and the plant must be designed correspondingly (e.g. pressure loss in lines depending on nominal diameter and length).

Both, the designer and the user are responsible to make sure that the whole plant including the metering

pump is constructed so that neither plant equipment nor buildings are severely damaged in the case of chemical leakage due to the failure of wear parts (e.g. diaphragm rupture) or burst tubing. When constructing chemical plants, the installation must be carried out so that no consequential damages appear which are unreasonably high even if the metering pump fails. We recommend installing leakage probes and containment tanks.

Metering pumps are produced according to highest quality standards and have a long service life. Nevertheless some parts are subject to wear (e.g. diaphragm, valve seats, valve balls). To ensure long operating life, visual checks are required regularly. Operating and maintenance personnel must be able to access the pump easily. Periodic maintenance protects the metering pump against shutdowns.

To increase the metering accuracy and reliability, we recommend using additional fittings. These include backpressure valves, relief valves, leakage probes, and chemical low level indicators, as shown in the installation example on the following page.

Always use appropriate tools for the installation of plastic connecting parts. In order to avoid damage, never apply excessive force; plastic parts (especially PVC parts) can be screwed and unscrewed more easily if the thread is lubricated with vaseline or silicone grease before.

*Note:* For this purpose, the compatibility with the chemical to be metered must be checked.

Ambient temperatures exceeding 40°C are not permitted. Radiant heat of apparatus and heat exchangers must be kept in limits allowing the pump to sufficiently dissipate its own heat. Exposure to direct sunlight should be avoided especially for metering pumps with plastic housings because the black plastic material can be damaged. If the pump is installed outside, provide an enclosure to protect it against weather.

The pump must be installed with vertical suction and discharge valves in upright position. To ensure stability of the pump screw it onto an appropriate base.

System piping must not exert any force to the connections and valves of the metering pump.

To avoid incorrect metering after the process is finished, provide an electric and hydraulic interlocking system.

### Installation example

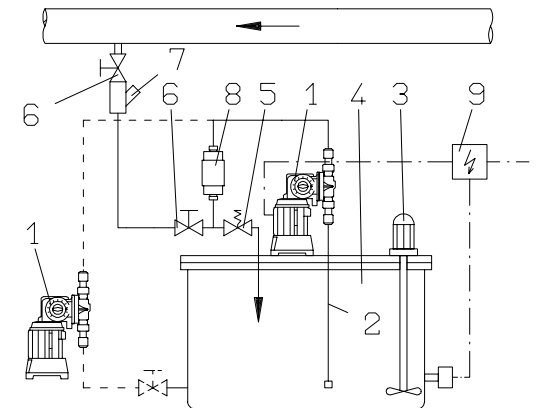

### Legend

1	Minidos A	MB 1 03 02
2	Suction line	MB 1 22 01
3	Electric agitator	MB 1 36 03
4	Tank	MB 1 20 01
5	Relief valve	MB 1 25 01
6	Diaphragm shutoff valve	MB 1 24 01
7	Injection nozzle	MB 1 23 01
8	Pulsation dampener	MB 1 27 01
9	Switch box	

### Drain pipe

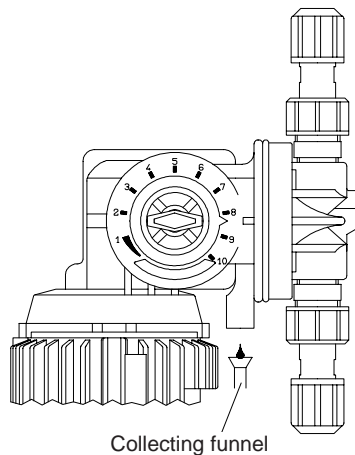

The drainage or leakage must be run from the separating chamber downwards to the containment tank. By no means must the drain pipe be returned to the medium directly through the tank cover since otherwise effervescent media might enter the pump gear. The drain pipe must only be routed into a collecting tank free of gases (with a downward slope), or to a collecting funnel - also with a downward slope - above which the pipe ends at a sufficient distance. Leakage can then be returned via the funnel through the tank cover. Furthermore, any existing leakage can be seen at the collecting funnel.

### 4. Electrical connection of the pump

- The electrical connection of the pump must be made according to the local rules and may only be carried out by technical personnel.
- Cable type and cable cross section of the supply lines must be selected according to the motor data.
- The cable passage to the motor terminal box must be made professionally. We recommend gland screw connections with traction relief.
- The required protection class must be ensured by professional installation of the electrical connections.

### Electrical connection data

Pump model	Voltage [Volt]	Power [Watt]	Current [A]
A3, A8, A14	400/230	30	0.23/0.40
A5, A24, A40	50 Hz	50	0.30/0.52
A3, A8, A14	440/254	40	0.24/0.42
A5, A24, A40	60 Hz	60	0.30/0.52
A3, A8, A14	400/230	40	0.22/0.38
A5, A24, A40	60 Hz	60	0.29/0.50
A3, A8, A14	230/1~	25	0.35
A5, A24, A40	50 Hz	50	0.45

### Wiring diagram of the drive motor

- 3-phase supply

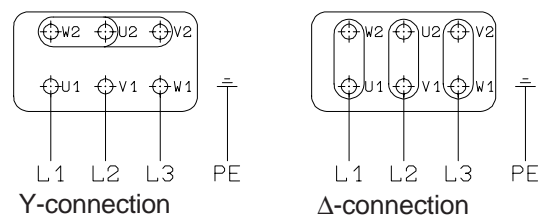

- A.C. power supply with motor in Steinmetz connection

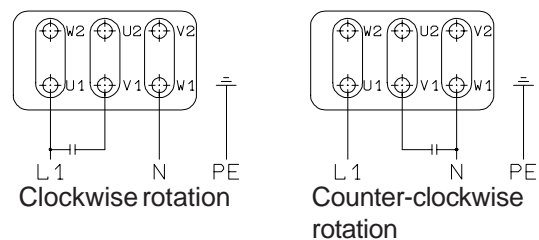

- Special versions

For other special versions please refer to the corresponding separate circuit diagrams.

- Electrical servomotor ATE

The technical data and wiring diagrams are shown on pages BW 1 03 02 / 7-10.

## 5. Safety instructions

- ⇒ When working on chemical equipment, observe the local safety rules (e.g. wear personal protective clothes).
- ⇒ Before working on the metering pump and plant, disconnect it from the main power supply and secure it against reconnection. Before the voltage supply is switched on again, the metering lines must be connected so that chemical left in the metering head cannot spurt out.
- ⇒ The metering head of the pump as well as connections and lines in the plant may be under pressure. Working on the metering plant requires special safety precautions and may only be carried out by instructed technical personnel.
- ⇒ Before startup, all screwed connections must be checked for correct tightness and, if necessary, must be tightened up using appropriate tools.
- ⇒ If connections at the metering head are unscrewed during operation for venting or other reasons, leaking chemical must be removed completely. This is the only way to avoid the danger of physical injury and corrosion at the metering pump. Leaking chemical may also destroy the diaphragm at its mounting points.
- ⇒ When changing the chemical, check whether the materials used for the metering pump and the other plant parts are chemically resistant. If there is the danger of a chemical reaction between different media, a thorough cleaning first is mandatory.
- ⇒ The base area of the pump must be kept free to ensure sufficient air circulation for cooling of the motor. If liquid is likely to accumulate below the pump base, install the pump at a higher position.

## 6. Injection fitting assembly

Injection nozzles prevent the liquid from returning to the pump by using either a spring-loaded ball valve or a hose valve. We recommend injection from bottom to top to allow air to escape thereby avoiding chemical precipitation. Experience with the particular metering chemical and all appropriate characteristics must be taken into account.

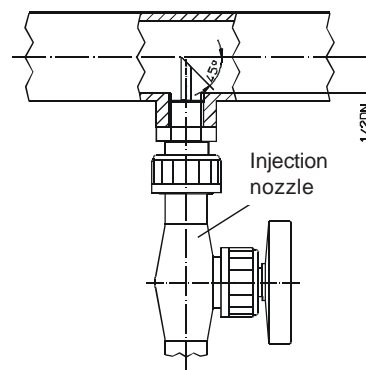

## 7. Startup

1. Before starting the metering pumps all works mentioned in section 3 "Installation" must be carried out. At the same time the safety instructions must be observed.
2. The metering pump is switched on by a control to be installed externally.
3. The manual or electrical capacity adjustment must be set to maximum stroke to improve priming. During first priming no backpressure should be applied. For this purpose we recommend to install a relief valve on the discharge side of the metering pump.
4. A previously installed priming aid must be filled with chemical first. If the pump is not priming, turn out the discharge valve and fill water or chemical (if not dangerous!) into the metering head. Remount valve and start priming.
5. If a venting facility is available as separate unit, open it and wait until liquid escapes. Then close it again. In the case of effervescent liquids allow the liquid to escape permanently (approx. 1 drop for 1...3 strokes)..

6. When correct operation is achieved, set to required output by means of the adjusting knob or by remote adjustment. For approximation refer to the performance curves shown in MB 1 03 02. Depending on the installation and the chemicals used, these values may differ and must be checked under operating conditions.
7. The manufacturer of the metering equipment is not responsible for damages due to excessive or low flow rates resulting from faulty pump settings or incorrect and insufficient installation of peripheral fittings.
7. The stroke adjustment is now set to maximum while the motor is running.
8. Now the head is remounted by tightening it carefully with the screws. Apply a tightening torque of approx. 125 Ncm.
9. After connecting the metering lines the pumps is started as described in section 7, startup.
10. If the diaphragm wear is excessively high, try to find out the reason. Please refer to the following section, troubleshooting.

## 8. Lubrication

### *Lubrication*

The diaphragm metering pump MINIDOS requires little maintenance. The gear of the pump is provided with molybdenum-disulphite lubricant for long service life. In the case of difficult operating conditions or high ambient temperature the grease should be renewed about every 5,000 operating hours. Use "Molycote BR2plus" or "OKS400" for this purpose.

**Caution:** This drive is not suitable for oil lubrication!

### *Replacing the diaphragm*

In the case of a rupture the diaphragm can be replaced as follows:

1. The chemical contained in the metering line is drained so that the metering lines become pressureless. Please observe the aforementioned safety instructions for this purpose.
2. The flow rate of the metering pump is set to zero while the motor is running. Thus the diaphragm is moved to its front end position.
3. The head is removed using an appropriate tool (monkey wrench with 3 mm hexagonal recess).
4. Grasped at the edge, the diaphragm can now be turned out counterclockwise. Check the existing support plate for damage (in the case of diaphragm dia. 38 mm) and replace, if necessary.
5. Before installing the new diaphragm the diaphragm flange section must be cleaned of the chemical. Otherwise the diaphragm might be attacked from the rear side.
6. The new diaphragm is turned in clockwise until it sits close.  
Make sure that the possible existing support plate is positioned correctly.

## 9. Troubleshooting

TYPE OF FAULT	POSSIBLE CAUSE	RECOMMENDED ACTION
Pump not delivering.	Valves leaking.	Clean and remove air from valves. (See also startup of pump). Tighten screw connections.
	Valves incorrectly installed.	Reassemble valves. Ensure that the valve balls are located above the valve seats.
	Suction filter, foot valve or suction pipe leaking or blocked.	Clean and seal suction line.
	No stroke movement.	Return spring broken. Replace spring. Consider density of the chemical! Suction lift too high.
Pump delivering too little or irregularly.	Valves blocked or leaking.	Clean and re-seal valves.
Pump delivering too much.	Pressure on suction side too high (pump siphoning).	Install backpressure valve in discharge line.
Frequent diaphragm ruptures.	Diaphragm was not screwed into diaphragm rod as far as stop.	Screw in new diaphragm as far as stop.
	Injection nozzle blocked.	Clean injection nozzle; fit larger one, if necessary.
	Pressure peaks because metering line is too long or too narrow.	Change line or install pulsation dampener. For increased safety install relief valve (see installation example).
Pump very noisy.	Roller bearing defective.	Replace roller bearing.
	Gear without molybdenum-disulphite.	Renew e.g. Molycote.
Motor hums and doesn't start.	Wrong connection.	Check electrical wiring.
	Capacitor defective, wrong size or connected incorrectly.	Connect capacitor correctly or replace it, if necessary.
	Pressure too high.	Check process.

If the problem cannot be corrected on the basis of the above data, return the pump to the factory or contact our Technical Sales Service for further measures. Repairs will be carried out immediately.

**Keep the operating instructions of the metering pump and the accessories readily accessible.**

**List of contents**

1. General
2. Technical data
3. Installation
4. Safety instructions
5. Wiring diagrams
6. Startup
7. Manual adjustment
8. Maintenance

**1. General**

The metering pump is installed according to the relevant operation instructions. The following instructions refer to the electrical ATE servomotor, types AR 30W.. and AR 30W..S, only.

**3. Installation**

The ATE servomotor is connected to the pump and adjusted in the factory.

For installation a sufficient mounting space of at least 150 mm must be provided for later maintenance works.

The electrical connection of the ATE drive must correspond to the local rules and may only be carried out by technical personnel.

The following wiring diagrams show the two basically realizable possibilities of connection.

Cable type and cable cross section must be chosen according to the motor data.

The cable passage to the motor terminal box must be made professionally. We recommend gland screw connections with traction relief.

The required protection class must be ensured by professional installation of the electrical connections.

Please take into account that the ATE drive can only be controlled with the main motor running, i.e.: the ATE drive must be locked electrically. Otherwise the adjusting eccentric wears out frequently or is destroyed.

**2. Technical data**

Type	AR 30W..	AR 30W..S
Design	Reversible a.c. motor with self-locking reduction gear.	
Use	for controllers with switching output (3-point control)	for controllers with continuous output (2...10V or 4...20mA)
Auxiliary voltage	230V ~ ± 15% 50...60 Hz	24V ~ ± 20% 50...60 Hz
Control		2...10V or 4...20mA
Power consumption	2 W	7 W
Regulating time/bevel	360s / 270° = 0...100%	
Position repeating signaling for remote display	Potentiometer 0.5 W 0...1000 Ω = 0...100%	0...620mV = 0...100%
Limit switch	Internal limit switch for limiting the angle of rotation. Signaling of final position via terminals 16 and 17	Internal limit switch for limiting the angle of rotation.
Protection class	IP 55 (EN 60529)	
Ambient temperature	-20 ... 60°C	
<b>Option</b>		
2nd potentiometer	0...1000 Ω 0.5 W	
Limit switches (2 off)	max. 250V 1A	

#### 4. Safety instructions

The below mentioned safety instructions refer to the ATE servomotor. Furthermore, the notes listed in the operating instructions of the metering pump are also valid for this extended version.

- ⇒ When working on the metering equipment, observe the local safety rules.
- ⇒ Before working on the metering pump and the ATE servomotor, disconnect the main power supply and protect it against reconnection.
- ⇒ Adjustment works in the interior of the ATE drive must be carried out carefully. Connections and internal limit switches might be "alive".
- ⇒ Additional limit switches might be "alive" even with the auxiliary voltage switched off.
- ⇒ After installation works at the ATE servomotor or before startup remount the cover.

#### 5. Wiring diagrams

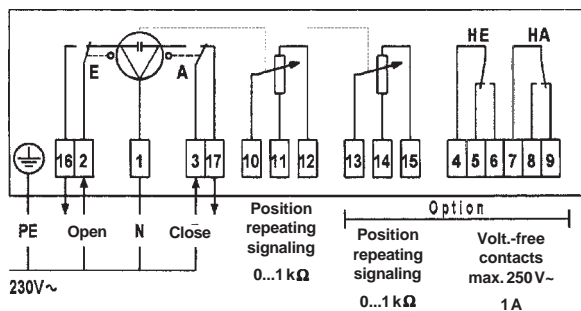

Control by 230V 50...60Hz supply voltage

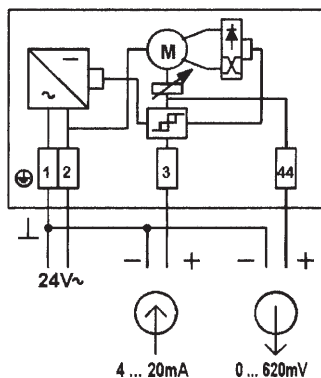

Control by 4...20mA standard signal  
(24V 50...60Hz supply voltage)

#### 6. Startup

Switch on the main drive motor of the metering pump. With an electrical interlocking system, only then can the ATE drive be adjusted.

To check the direction of rotation send short control pulses to the ATE servomotor.

If the direction of rotation is wrong, the supply lines (terminals 2 and 3 in the case of direct controls) are reversed.

The ATE servomotor must be moved to the final positions in order to check the limit stop mechanism of the integrated limit switches. When leaving the factory, the angle of rotation is 270°. If required, the angle of rotation and thus the maximum flow rate can be restricted. To achieve this, the upper trigger cam is shifted by the required value.

#### 7. Manual adjustment of the ATE drive

In the case of an electrical failure of the ATE servomotor, it can be adjusted manually by means of a hand crank. This part is available as accessory (Part No. 32.587).

For manual adjustment proceed as follows:

1. Switch off power supply to the ATE servomotor.
2. Remove ATE cover.
3. Switch on main drive motor.
4. Insert hand crank in corresponding opening, as shown below, and turn into desired direction.  
Attention: The final positions must not be crossed !
5. After manual adjustment remount the cover.

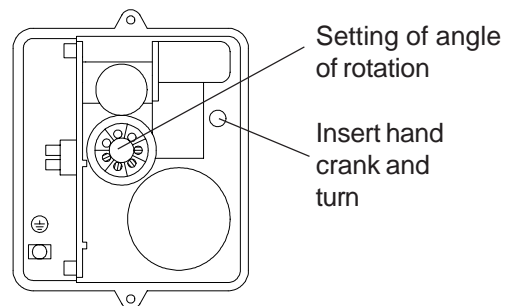

#### 8. Maintenance

The ATE servomotor is lubricated for life before leaving the factory. Nevertheless regular checks are recommended if the drive works under difficult operating conditions, such as a high ambient temperature or continuous operation. For relubrication of the ATE gear use molybdenum disulfite, e.g. "Molycote BR2plus" and "OKS400".

**Keep the operating instructions of the metering pump and the accessories readily accessible.**

**List of contents**

1. General
2. Technical data
3. Installation
4. Safety instructions
5. Wiring diagrams
6. Startup
7. Maintenance

**1. General**

The metering pump is installed according to the relevant operation instructions. The following instructions refer to the electrical ATE servomotor, types WAN 1 und WAN 1-S.

**3. Installation**

The ATE servomotor is connected to the pump and adjusted in the factory.

For installation a sufficient mounting space of at least 150 mm must be provided for later maintenance works.

The electrical connection of the ATE drive must correspond to the local rules and may only be carried out by technical personnel.

The following wiring diagrams show the two basically realizable possibilities of connection.

Cable type and cable cross section must be chosen according to the motor data.

The cable passage to the motor terminal box must be made professionally. We recommend gland screw connections with traction relief.

The required protection class must be ensured by professional installation of the electrical connections.

Please take into account that the ATE drive can only be controlled with the main motor running, i.e.: the ATE drive must be locked electrically. Otherwise the adjusting eccentric wears out frequently or is destroyed.

**2. Technical data**

Type	WAN 1	WAN 1-S
Design	Reversible a.c. motor with self-locking reduction gear.	
Use	for controllers with switching output (3-point control)	for controllers with continuous 0(4)...20mA output
Auxiliary voltage	230V~ ± 10% 50...60 Hz Other voltage on request	230V~ ± 10% 50...60Hz
Control		0(4)...20mA
Power consumption	approx. 11.5 W	
Regulating time/bevel	360s / 270° = 0...100%	
Position repeating signaling for remote display	Potentiometer 0.5 W 0...1000 Ω = 0...100%	0(4)...20mA (only as option)
Limit switch	Internal limit switch for limiting the angle of rotation. Signaling of final positions via terminals 4 and 5	
Protection class	IP 54 according to DIN 40050	
Ambient temperature	max. 60°C	
<b>Option</b>		
2nd potentiometer	0...1000 Ω 0.5 W	
Limit switches (2 off)	max. 250V 1A	

#### 4. Safety instructions

The below mentioned safety instructions refer to the ATE servomotor. Furthermore, the notes listed in the operating instructions of the metering pump are also valid for this extended version.

- ⇒ When working on the metering equipment, observe the local safety rules.
- ⇒ Before working on the metering pump and the ATE servomotor, disconnect the main power supply and protect it against reconnection.
- ⇒ Adjustment works in the interior of the ATE drive must be carried out carefully. Connections and internal limit switches might be "alive".
- ⇒ Additional limit switches might be "alive" even with the auxiliary voltage switched off.
- ⇒ After installation works at the ATE servomotor or before startup remount the cover.

#### 6. Startup

Switch on the main drive motor of the metering pump. With an electrical interlocking system, only then can the ATE drive be adjusted.

To check the direction of rotation send short control pulses to the ATE servomotor.

If the direction of rotation is wrong, the supply lines (terminals 2 and 3 in the case of direct controls) are reversed.

The ATE servomotor must be moved to the final positions in order to check the limit stop mechanism of the integrated limit switches. When leaving the factory, the angle of rotation is 270°. If required, the angle of rotation and thus the maximum flow rate can be restricted. To achieve this, the upper trigger cam is shifted by the required value.

#### 5. Wiring diagrams

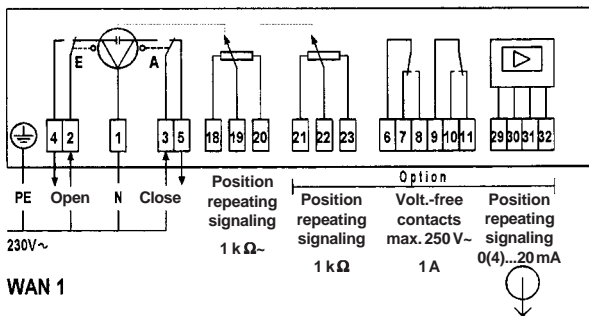

Control by 230V/50...60 Hz supply voltage

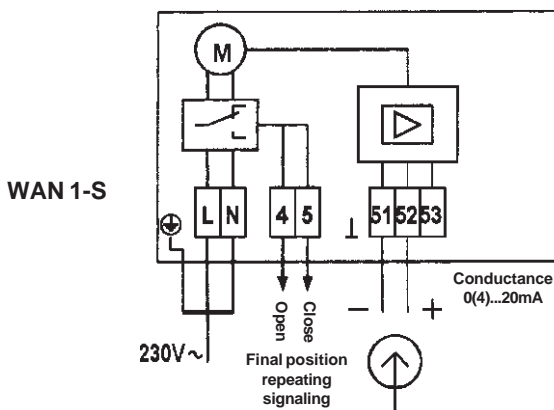

Control by 0(4)...20mA standard signal